

# OPERATING INSTRUCTIONS



## TRACTOR-MOUNTED STUMP CUTTER LASKI FZ560T-RC FZ560 T-M

*Orig. version: 5. 2010*



EUROPEAN UNION  
EUROPEAN REGIONAL DEVELOPMENT FUND  
INVESTMENT IN YOUR FUTURE



## Foreword

Thank you very much that you have just purchased our product, the stump cutter FZ560T. Our company has been engaged in production of equipment for stump cutting, wood residue crushing and disposal for many years and has gained considerable experiences in this field. Quality of our small and also powerful machines is proven in 40 countries of Europe and Asia we export to.

Permanent innovations of the Laski manufacturing assortment have been crowned by the most important awards in the company's history, the golden medals Grand Prix, gained for its complete family of products at the international shows Techagro und Silva Regina in Brno:

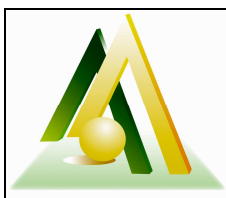

Grand Prix Techagro	1998
Grand Prix Silva Regina	2002
Grand Prix Silva Regina	2008

This manual brings important instructions for users, i.e. instructions for putting the machine into operation, work safety and operating experiences. You will learn how to carry out maintenance, repairs and servicing and who is authorised for doing checks and other actions on the machine.

Your local dealer will give you this manual with instructions for operation and maintenance while taking this new machine over. Make sure if you understand everything. If not, do not hesitate and contact your dealer and ask him for further explanation. It is very important for you and your work safety to understand all instructions given in this manual.

The firm Laski s.r.o. does not bear any responsibility for any claims resulting from disobedience to the instructions given in this manual.

This operation manual includes also work safety instructions in various parts of its text. If there is any work safety rule or instruction in general description, then this instruction is indicated with the following symbol:



## Contents

Foreword .....	2
Contents .....	3
EC Conformity Declaration .....	5
Product Identification .....	7
Work Safety Instructions .....	8
Utilisation .....	8
Not Allowed Use .....	8
Generally .....	9
Work Safety Symbols .....	14
Precautions in Design .....	15
Controls .....	16
Use .....	18
Transport Safety .....	18
Cardan Shaft Adjustment .....	19
Storage .....	20
Before Putting into Operation .....	20
Coupling to Tractor .....	20
Putting into Operation .....	22
Putting out of Operation .....	24
Emergency Situations .....	24
Cutting .....	24
Noise and Vibrations .....	26

Technical Description .....	26
Technical Parameters .....	28
Maintenance .....	29
Lubrication .....	30
Replacment of Blades and Regrinding .....	31
Maintenance Intervals .....	33
Failures and Troubleshooting .....	33
Waste Disposal .....	34
Warranty .....	34
Maintenance and Servicing .....	35

# EC Conformity Declaration

**EC CONFORMITY DECLARATION**  
 issued in compliance with applicable EC Directives

We, as the manufacturer, **LASKI, s.r.o.**  
 Blištka 263/16  
 Smržice  
 CZ-798 17  
 CRN: 45479593

declare hereby that our product  
 - designation: **Tractor-mounted Stump Cutter**  
 - type: **FZ 560 T-RC**

complies with the given EC Directives:  
 2006/42/EC – machinery  
 2004/108/EC - EMC  
 1999/5/EC - ACT as amended

List of technical standards, specifications and harmonised norms used for assessment of its conformity:  
 EN ISO 12100-1,2, EN ISO 13732-1,  
 EN 953+A1, EN 982+A1, EN ISO 4254-1,  
 EN ISO 11201, ISO 11 684, EN 55011,  
 EN 60950-1, EN 301489-1,3, EN 300220-3

Basic technical parameters:

Parameter	Unit	Value
Length	mm	2180
Width	mm	1040
Height	mm	1735
Weight	kg	526
P.T.O. shaft speed	rpm	540
Cutting range above/under ground	mm	0,7 / 0,6
Remote control	-	SCANRECO RC 400 (Sweden)
Transmitter frequency	MHz	433,05 – 434,79
Transmitter output	mW	max. 10

Completion of technical documentation: **Ing. Jiří Kvasnička**  
 Petra Bezruče 205  
 CZ-664 43 Želešice

In Smržice, on 6.4.2010

*Kvasnička*  
 -----  
 Ing. Jiří Kvasnička

## EC CONFORMITY DECLARATION

issued in compliance with applicable EC Directives

We, as the manufacturer,

LASKI, s.r.o.  
Blištka 263/16  
Smržice  
CZ-798 17  
CRN: 45479593

declare hereby that our product

- designation: Tractor-mounted Stump Cutter  
- type: FZ 560 T-M

complies with the given EC Directives:

2006/42/EC – machinery

List of technical standards, specifications and harmonised norms used for assessment of its conformity: EN ISO 12100-1,2, EN ISO 13732-1, EN 953+A1, EN 982+A1, EN ISO 4254-1, EN ISO 11 201, ISO 11 684

Basic technical parameters:

Parameter	Unit	Value
Length	mm	2180
Width	mm	1040
Height	mm	1735
Weight	kg	530
P. T.O. shaft speed	rpm	540
Cutting range above/under ground	mm	0,7 / 0,6

Completion of technical documentation:

Ing. Jiří Kvasnička  
Petra Bezručů 205  
CZ-664 43 Želešice

In Smržice, on 15.2.2010

Ing. Jiří Kvasnička

## Product Identification

Our product is identified with its serial number stamped both on the type plate and on the chassis.

Upon take-over of the product we recommend you to fill required data in the following form concerning the given product and your dealer.

Type of product: .....

Serial number of product: .....

Dealer's address: .....

Address of authorised service: .....

Date of delivery: .....

Warranty expiration date: .....

Interruption of warranty period: .....

The product type plate is located on the chassis.

It includes:

- manufacturer's data
- type
- serial number
- year of manufacture
- weight of machine
- product designation (CE)



## Work Safety Instructions

### Utilisation

This product is designed for cutting a stump with its above-ground part up to +700 mm and its under-ground part in a max. depth of -600 mm under the ground level while being coupled to a three-point hitch, category 1 or 2 and to the PTO shaft assembly for 540 rpm.

This stump cutter is designed for working in the field with max. inclination as allowed for the tractor.

This stump cutter is designed both for manual and remote control operating at transmitter frequency ranging from 433,05 to 434,79 MHz.

### Not Allowed Use

- This machine cannot be used for cutting of dozy stumps which could be released and pulled out by the blades.
- Avoid any cutting if there can be some foreign matters and objects, such as metal, glass cullet, stony debris, ceramics etc. hidden in the stump.
- It is strictly forbidden to start working with removed guards, particularly with a missing rear guard of the cutting head or if this guard does not cover the head properly.
- It is not allowed to use the cutter if other persons are within the hazardous area.
  - It is strictly forbidden to work with the coupled machine crosswise to the hillside.

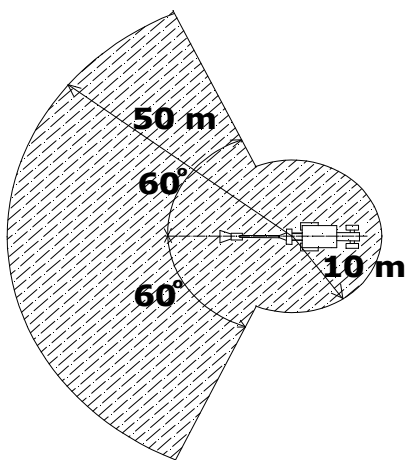

The hatched space means the hazardous area around the tractor and the cutter.

The centre of circles, as a centre of the hazardous area, is in the centreline the tractor and the cutter and in the connecting line of the bottom draw rod pins.

Any working crosswise to the hillside may bring instability of the tractor due to cutter jib swinging and eventual hits of the blades on the stump.



## Generally

- Do not use this machine without prior reading this manual. The user/owner of this machine is obliged to instruct attendants about relevant instructions for its operation in a demonstrable way.
- This manual should be available/accessible for attendants any time.
- This machine is allowed to be operated only by an operator who is over 18 yrs old, physically and mentally capable and demonstrably instructed about its operation. In addition to that, he should have a respective driver's license, group B or T (according to a tractor type).
- While working, wear always personal protective equipment - protecting shield or goggles, protective gloves, working shoes and working clothes properly buttoned. Avoid wearing free parts, such as ties, scarves and shawls, belts etc. Use hearing conservation in dependence on the tractor noise level.
- Every operator of this machine is fully responsible for any injury or damage caused to the third persons within the operating reach of the machine.
- While working, the operator should stand:
  - type FZ 560 T-M: behind the cutter rear guard in its working and secured position;
  - type FZ 560 T-RC:  
at least 3 m away from the cutting head, see fig.
- Keep this machine beyond children's and unauthorised persons' reach. Avoid their presence while working.
- Type FZ 560 T-RC: before use, observe the working area if there is no similar equipment in service which may interfere with the cutter operation or if the cutter itself cannot interfere with the other appliances and health care facilities.
- Observe the working area. If any person, children or animals approach while cutting, then stop working immediately.
- Before working learn all functions of individual controls and safety elements and carry out functional checks before any use.
- Make sure if necessary operating and ancillary space is free and safe.
- At work in residential zones use the machine in accordance with regulations of the local authorities to avoid disturbing of local inhabitants (noise, flying chips).
- Before working make sure if the bottom edge of the adjustable guard covers the cutting head properly.
- While working keep an eye on chips gathering behind the cutting head. In case of excessive accumulation, stop the PTO shaft drive and wait for running the head out. When the head stops, remove excessive chips.
- This manual describes problems and faults that may occur at work and that could be remedied by an instructed person. In case of other problems and faults do not hesitate and contact the manufacturer. He is always ready to help you.
- Do never any technical changes or any actions that are neither given in this manual nor allowed by the manufacturer. This machine, if not correctly installed or adjusted, may run without problems now but in the future any of important parts could get out of order or do fatal damage.
- For replacement of worn or damaged parts use always original spare parts only.

- The manufacturer does not bear responsibility for any damages or injures to the third persons, or to other equipment, resulted from disobedience to instructions given in this manual.
- Do not put any objects or tools on the machine.
- Do not leave the machine unattended – pull out the tractor ignition key.
- When handing the machine over to another person make sure if all controls, guards and other safety elements are complete and properly installed. They serve for your safety.
- Keep the given intervals for checks of bolted joints.
- Always after work clean up all parts of the machine (brush, cleaning rag).
- Any actions or servicing on the machine are allowed to be done only if the tractor engine is turned off, its ignition key is pulled out and the given tractor should be blocked properly against unwished motion (parking brake, scotch blocks). Furthermore, the coupled machine, respectively the three-point linkage, should be blocked against unwilling sinking. If the cutting head should remain lifted then block the machine jib separately.
- Type FZ 560 T-RC: turn off the remote control box and pull out the ignition key.
- When handing the machine over to another person make sure if all controls, guard emergency switches and other safety elements are complete, functional and properly installed. They serve for your safety.
- Do not use or attempt to start the stump cutter without the cutter guards, engine covers and access covers securely in place. Failure to do so may result in personal injury or loss of life
- Keep the given intervals for checks of bolted joints.
- Keep the battery of the remote control box fully charged.
- Do not use petrol and similar oil products as a cleaning agent.
- Keep the machine beyond reach of open fire.
- Any transport of persons or of any load on the machine is not allowed.
- Some parts of the machine may run warm (gearings, hydraulics). Do not touch them when the machine is still running or having been just stopped.
- Do not let the input shaft running in speed exceeding its rated value.
- The joint shaft has to be always covered by effective guards with fixing chains.
- Do not attempt to detect contingent hydraulic oil leakage directly by hand. Use always a piece of cardboard, wooden board etc. – risk of injury by oil under high pressure.
- Carry out regular checks of hydraulic hoses for their actual condition (damage, cracks, wear).
- While being coupled to a tractor, do not use the machine in confined or ill-ventilated spaces. Exhaust gases from the tractor include also toxic carbon monoxide which is colourless, odourless and tasteless.
- Do not use the machine under conditions of low visibility, especially at foggy weather, when you may overlook persons coming.
- Do not carry out any repairs that are specified for authorised services only.
- Do not carry out any repair where its solution exceeds your experiences.
- In case of any uncertainty with operation of this machine ask your dealer to show proper operation in practice.
- While working, particularly while transporting the coupled machine, respect all the applicable instructions given in the tractor manual.

- Every training course for attending personnel should include also practical operation under supervision of an experienced person or your dealer and necessary work safety instructions.
- Before working learn all functions of individual controls, both of the machine and of the tractor, particularly after turning the PTO shaft off.
- While cutting, do not enter the space in direction of ejected wooden chips.



Place for attendance with remote control

- While cutting with remote control, the operator should stand at least 3 m away, see fig.



Place for attendance with manual control

- Before any displacement of the machine to another workplace the operator is obliged: type FZ 560 T-M: to tip up and to secure properly the rear guard to the cutter

- arm; to turn off the cutting head drive and to block the head in safe condition;
- type FZ 560 T-RC: to turn off the remote control box and to hang it up on the supporting foot framing; to turn off the cutting head drive and to block the head in safe condition;
- Keep this machine beyond children's and unauthorised persons' reach. Avoid their presence while working.
- Observe the working area. If any person, children or animals approach while cutting, then stop working immediately.
- Be aware of ejected particles. They have substantial kinetic energy. If the wooden material to be cut contains not allowed parts, such as metal, sand, glass etc., then such objects can reach a longer distance than wooden chips. Before working make sure if the bottom edge of the adjustable guard covers the cutting head properly in order to reduce unwished ejection.
- The operator of this machine is fully responsible for any injury or damage caused to the third persons within the operating reach of the machine.
- At work in residential zones use the machine in accordance with regulations of the local authorities to avoid disturbing of local inhabitants (noise, flying chips).

**While working the operator is obliged:**

- to use only such a cutter which is in optimal operating condition, not damaged through transport, storage or from previous operation,
- to check up the working area, respectively soil bearing capacity, before work,
- to avoid working on wet terrain, steep slopes and close to trenches with risks of instability,
- to avoid working with inclination exceeding the limit as allowed for the tractor,
- to check functions of all controls and safety elements before putting the machine into operation,
- to avoid disturbing other people with noise, exhaust gases or ejected flying particles (at windy weather),
- to keep traffic rules and local regulations when going or working on or nearby public roads.
- Do not leave the machine unattended – pull out the tractor ignition key.
- While working, wear always personal protective equipment - protecting shield or goggles, protective gloves, working shoes and working clothes properly buttoned. Avoid wearing free parts, such as ties, scarves and shawls, belts etc. In case of longer hairs use always a proper head piece. Otherwise, such a person is not allowed to operate this machine.
- Keep work safety symbols in proper order.
- Check out the stump to be cut and remove all undesirable objects. If you see such particles in ejected chips stop working immediately.
- In case of any problems and faults at work do not hesitate and stop the machine immediately. Any fault, particularly on rotary parts, may cause fatal and dangerous situations.
- This manual describes problems and faults that may occur at work and that could be remedied by an instructed person. In case of other problems and faults do not hesitate and contact the manufacturer. He is always ready to help you.
- Do never any technical changes or any actions that are neither given in this manual nor allowed by the manufacturer. This machine, if not correctly installed or adjusted, may run

without problems now but in the future any of important parts could get out of order or do fatal damage.

- Pay regular attention to all joints and bolts. Keep them properly tightened.

### **Motor Vehicle Construction and Use Regulations**

- ❑ This stump cutter is allowed to be coupled to a tractor provided that actual weight of the tractor in such an attachment does not exceed its maximum permissible value and actual front axle load does not fall under 20% of its gross weight.
- ❑ At public road transport the stump cutter rear must be completed with a portable set of rear lamps and reflector glasses supplied by the manufacturer.
- ❑ Any public road transport without this portable set of rear lamps and reflector glasses is not allowed – these lamps must always be turned on.
- ❑ This portable set should comprise:
  - 2 plates with red-white hatching with reflecting surface
  - 2 rear combined lamps with side, stop and direction indicator lights
  - 2 rear triangular red reflector glasses
  - 1 warning triangle for marking of slow-moving vehicles
- ❑ The distance between the outer edge of lamps and reflector glasses in the portable set and the contour line of the vehicle should not exceed 400 mm.
- ❑ At public road transport this machine must be lifted up in its transport position, see Operating Instructions.
- ❑ The transport position means that the stump cutter is lifted up; clearance height under its supporting feet is approximately 300 mm; the cutter jib with the cutting head suspension is retracted to its minimum length; the supporting console is attached to the suspension; the PTO drive is turned off; all controls are set in their neutral position; all the portable lamps are plugged in the tractor 7-pin socket.
- ❑ While working on public roads, the amber light on the tractor cab must be turned on.
- ❑ The max. permissible speed of the stump cutter for transport on public roads is not explicitly specified – a valid value, see the max. permissible speed as specified for the tractor.
- ❑ Should the max. speed sign on the tractor be covered by the coupled stump cutter, then it should be attached to the left hatched plate on the cutter rear.
- ❑ Always before coming to a public road it is necessary to remove all mud, especially from the tractor tires and accumulated sediments from the cutter.
- ❑ At public road transport the driver must keep the utmost diligence due to the fact that the rear part of the coupled machine swings out while manoeuvring.
- ❑ At public road transport the tractor driver must keep all local regulations valid for public roads.

## Work Safety Symbols

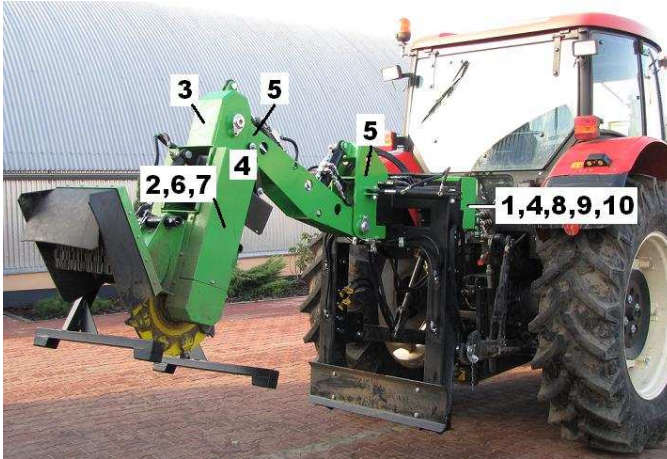

This article introduces work safety symbols (pictographs) used on this machine. Under the given pos. number there is their location on the machine. These work safety symbols warn the operator against risks connected with the machine use. Your respect to the symbol meaning is a precondition for your work safety.

The user is obliged to keep all the work safety symbols legible, clear and undamaged. In case of any damage or illegibility ask your local dealer or an authorised service for a new relevant pictograph.

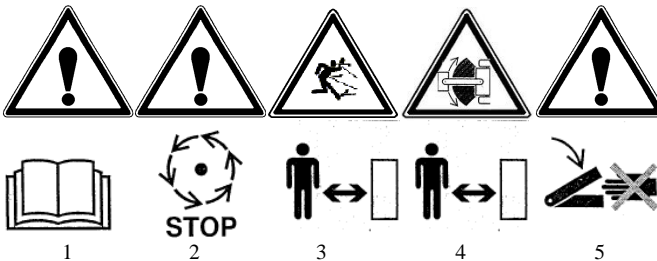

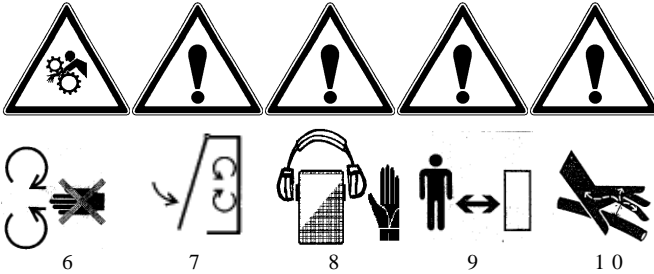

1. Read this operating manual before use.
2. Warning! Cutting head is running out.
3. Warning! Keep away – ejected objects hazard.
4. Warning! Keep away – this equipment swing out.
5. Warning! Keep extremities away – squeeze hazard.
6. Warning! Rotating parts – pull-in hazard.
7. Warning! Close all guards before starting the machine.
8. While working, wear personal protective equipment.
9. Keep safety distance.
10. Warning! Risk of high-pressure liquid leakage.

## Precautions in Design

This product is equipped with guards protecting the operator against unwished contact with moving parts of the machine. These guards are either fixed or bolted down and attached to the machine frame.



**The cardan shaft guard** is rigid and telescopic, covering the crucial part intended for cutting head driving.



The hydraulic locks on hydraulic cylinders are designed for limitation of unwanted sinking in case of a sudden failure or leakage in the hydraulic system.



Type FZ 560 T-M:  
 Face shield for attendance of hydraulic distributor.

## Controls

This stump cutter can be operated by means of controls in the tractor cab through the three-point linkage, see instructions for the PTO shaft and in the tractor manual.

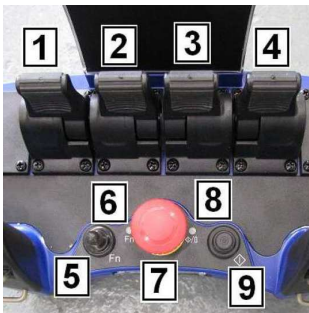

### Type FZ 560 T-RC:

1. Cutter arm left / right
2. Cutter arm up / down
3. Cutting head guard up / down
4. Jib up / down
5. Mode switching
6. Green LED – analog mode; LED does not shine: digital mode
7. STOP switch
8. LED for operation and battery condition
9. Activation switch



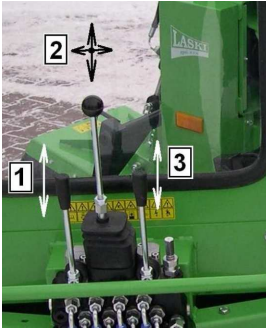

Type FZ 560 T-M:

1. Cutting head guard up / down
2. Jib control: up / down / right / left
3. Cutting head suspension forward / backward

## Common Cutter Controls

**Flow limiter** installed on the hydraulic cylinder for jib control. This limiter is preset by the manufacturer and further (contingent) readjustment can be done according to the tractor being actually used. It is in fact a one-side throttling valve reducing the jib speed downwards.



**Flow limiter** installed on the hydraulic cylinder for cutting head suspension control. It is intended for flow control according to actual wood quality to be cut.



**Valve for response speed control of hydraulics**



It is intended for reduction of oil flow going from the tractor into the cutter hydraulic system. This reduction is limited by actual capacity of the tractor oil pump.

## Use

### Transport Safety

This stump cutter is delivered completely mounted and ready to use. It is equipped with a supporting feet frame intended for easier putting the machine aside on flat surface.

The cutter type FZ 560 T-RC includes a separate remote control box with its battery charger.



After detachment of the cutter its supporting feet must be extruded properly and locked against loosening. This supporting frame is designed for keeping stability after putting the cutter aside.

## Cardan Shaft Adjustment

Before use it is necessary to check up cardan shaft adjustment as to its proper length. The cardan shaft length must be always adapted to the given tractor type.

Check up the cardan shaft length as follows:

- couple the cutter in the top and bottom draw rods of the tractor three-point linkage,
- lift up the linkage (for adjustment the cutter must be lifted in its top position)
- mark the position of the telescopic guard edge,
- having coupled and locked the machine to the tractor, connect the cardan shaft (extend it as necessary),

check up clearance between the guard edge and its previously marked and retracted position: it should exceed 200 mm,

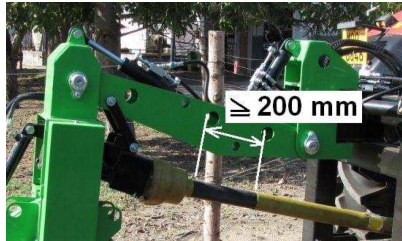

- let the linkage slowly sink in its bottom position (supporting feet frame in contact on the ground),
- let the cutter arm sink in its bottom position with the cutting head hinge as close as possible to the tractor (hydraulic cylinder fully extruded),
- swing out the jib to the left or to the right in its utmost position.

The bottom position is in fact the utmost position in which the cutting head can reach 600 mm (max. operating depth). For this purpose it will be useful to have the machine standing on the edge of a loading ramp. In this case it will be possible to reach the real bottom position. Again check up clearance between the guard edge: **min. clearance should exceed 20 mm**, see fig.

If not, the cardan shaft should be shortened accordingly, see instructions of the cardan shaft manufacturer. Otherwise it may bring damage on the shaft or even on the tractor.

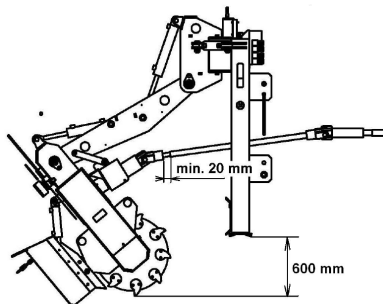

## Storage

*Store the stump cutter always in dry (sheltered) space to protect it against weather effects.*

- Keep the stored machine beyond unauthorised person's reach.
- Before storage clean all parts of the machine. Use pressure water for cleaning.
- Remove any spilled oil immediately and wipe off all oily spots.
- Exchange all damaged or worn parts. Use always original spare parts. For servicing or spare parts contact your dealer or an authorised service.
- Do not apply any grease or similar agents on elastic hydraulic hoses.
- Put the machine aside always on flat and solid surface.
- Do not put any objects or tools on the machine.

## Before Putting into Operation

- Before the first putting into operation check up the machine for contingent damages and completeness after its transport and storage.
- Check out tightening of bolted joints, especially of guards and completeness of other parts.
- Check out the cutting head for its condition (attachment and wear of blades, bolts, etc.). If the cardan shaft is not coupled yet, then it is possible to turn the cutting head.
- Check out condition of the blades. Replace them if worn or damaged.
- Should any damage on the cutting head be detected, it is forbidden to go on working.
- Check out movability of turnable parts respectively functionality of the machine.
- Check out work safety labels for completeness and legibility. Replace any damaged and illegible label, if necessary.
- Grease bearings and sliding parts according to the Lubrication Plan.
- Check out the hydraulic system for condition and contingent leakage.
- For replacement **use always original spare parts**. The rotary parts, such as cutting head and blades, **should be balanced properly**.
- All blades should be replaced always at the same time as a set. Pay special attention to their fixing bolts. Replace them if worn or damaged.
- Do not use petrol or similar inflammable matters as a cleaning agent.
- For tractor engine operation use Diesel fuel only (winter Diesel fuel according to season).
- It is strictly forbidden to do any technical changes on the machine.
- If any adjustment is required, do it always at standstill only. Remember blocking the jib/three-point linkage against unwilling sinking.
- Check out condition and proper tightening of V-belts. Too much slack brings negative impact on their service life.
- It is strictly forbidden to start the machine with removed guards.
- **Type FZ 560 T-RC**: remove the battery from the remote control box and let it recharged (incl. a reserve battery, if any).
- Put the battery in the remote control box and check out all remote control functions.

## Coupling to Tractor

Coupling of this cutter to a tractor can be done as an attachment in the top and bottom draw rods of the three-point linkage, category I or II. For the category II: attachment from the external side

by means of connecting pins,  $\varnothing$  27 mm. For the category I: attachment into a fork by means of a connecting pin,  $\varnothing$  22 mm.

According to an actual tractor tires size the connecting pins can be inserted into holes in two different heights.

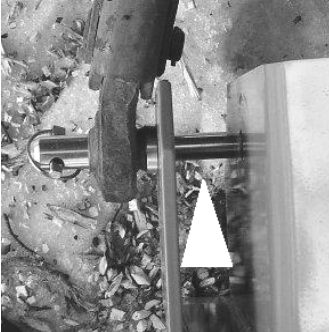

Attachment from the external side by means of connecting pins,  $\varnothing$  27 mm. The arrow head introduces the fork for attachment of the bottom draw rod. In both cases the pins must be properly locked by cotters against loosening.

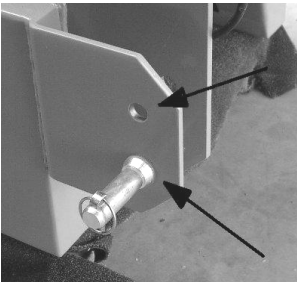

Height adjustment of the cutter connecting pins.



Attachment by means of consoles with quick-couplers.

Let the bottom draw rods sink until they are levelled with the connecting pins. Drive carefully back to the cutter hinge.

While going back and coupling, nobody is allowed to stand between the cutter and the tractor. Attach the bottom draw rods of the three-point linkage and lock its pins by cotters or put the pin through the draw rod ball. Lock the pin/draw rod against loosening.

**Plug the traffic lights of the cutter in the 7-pin socket on the tractor rear. Finally attach the joint shaft which has to be always covered by effective guards with fixing chains. First put the joint shaft on the angle gearbox spline shaft and then on the PTO shaft.**

**To control functions of the stump cutter it is necessary to plug the supply cable in the tractor cab socket. The cable is to be pulled through the cab rear window.**

**Any displacement of the cutter to another workplace, especially on public roads, should be carried out with the supporting console properly attached and locked against loosening.**



## Putting into Operation

- Remove the supporting console from the cutter and put it aside.
- Before start prevent other persons to enter the working area, see “Not Allowed Use.”
- Before start check up the working area and the stump to be cut. Select an optimal place for the tractor in terms of its stability at work.
- The tractor place should be freely accessible for contingent emergency cases at work.
- Check out the machine for completeness and proper coupling to the tractor.
- Make sure if necessary operating and ancillary space is free enough, particularly for manoeuvring of the jib, cutting head suspension and rear guard. Should this manoeuvrability be detected anyhow as limited, then it is forbidden to start working. In this case it is necessary to displace the tractor.
- Before start avoid any contact of the cutting head resting on the ground or on any hard objects – it must not be blocked anyhow.

- Put the rear guard down to cover the cutting head properly.
- When the cutter is properly coupled to the tractor, start the tractor and then turn on its PTO shaft which should run up gradually – increase shaft speed slowly up to its required/rated level.
- While turning the PTO shaft on, the attendant's place is in the tractor cab. When its rated speed is reached, the attendant should stand about 3 m away from the supporting feet frame, see fig., or behind the face shield for attendance (type FZ 560 T-M). In this case the face shield should be tipped in its working position.
- Keep an eye on continuity of the cutter run-up, in particular observe unwished vibrations during its initial run. In this case turn off the cutter immediately and contact an authorised service.



- Do not leave the machine unattended.
- If any person or animal enters the danger area while cutting, then stop working immediately, respectively turn the PTO shaft off.
- Before putting the cutter into operation the joint shaft has to be properly coupled to the PTO shaft and the cutter hydraulic system has to be connected with the tractor hydraulics through related quick-couplers on the tractor rear.



The cutter hydraulic hoses, respectively their quick-couplers, are colour-coded. The coloured cutter coupler should be connected to the tractor pressure line and the white-coded coupler is to be connected to the tractor hydraulic return line. The yellow-coded coupler should be connected to opposite couplers marked 3-4 or 4-5, see fig.

Should any height adjustment be required, then connect also the other two hydraulic hoses to the pressure line of the tractor hydraulics.

## Putting out of Operation

If you want to stop cutting, turn off the PTO shaft, turn off the pressure line of the tractor external hydraulics and reduce the tractor engine speed.

## Emergency Situations

**Put the cutter out of operation immediately in following cases:**

- If any person or animal approaches the working area while cutting, then stop working immediately.
- In case of any indisposition of the attendant.
- If any breakage, damage or disengagement occurs, stop cutting immediately.
- If you heard any strange noise or vibrations or felt a strange smell while cutting, then turn off the machine immediately and contact your dealer or directly the manufacturer.
- **In case of fire or breakdown, stop cutting immediately.**
- **In case of fire use foam extinguishers only.**
- If you cannot damp the fire down yourself, call for a fire brigade.

## Cutting

- This stump cutter is powered by the tractor PTO shaft. It designed for cutting a stump at speed of 540 rpm while being coupled to a three-point hitch, Continuity and stability of the torque transmission have direct impact on its service life.
- While cutting, it is necessary to keep the tractor engine rated speed and not to exceed the PTO shaft speed of 540 rpm.
- Start cutting at the distant stump edge and go on to the near stump edge.





- Set the cutter onto the stump, start cutting in a swinging way and take individual stump layers continuously off. Depth of individual cut should be about 20 mm, less at start.
- Check out proper attachment/position of the rear guard.
- Avoid any cutting if there can be some foreign matters and objects, such as metal, glass cullet, stony debris, ceramics etc. hidden in the stump.



**Wrong position of the rear guard**

- the guard is too high – wooden chips are flying away too far



**Right position of the rear guard**

- the guard traps ejected chips

Recommendations

- While cutting, do not let the PTO shaft speed exceed 540 rpm.
- Max. allowed joint shaft bending is  $\pm 20^\circ$ .
- Speed of motions can be set by the valve for response speed control of hydraulics.



Valve for initial adjustment of oil flow



Readjustment according to wood quality

## Noise and Vibrations

Operation of this stump cutter brings following emissions:

	Unit	Value
Noise $L_{Aeq}$ at idle:	dB	85,8
Noise $L_{Aeq}$ at work:	dB	88,4

All measurements taken in accordance with CSN EN ISO 11201 at tractor rated speed.

## Technical Description

This machine consists of following main parts:

- ❖ Supporting frame
- ❖ Jib suspension
- ❖ Jib
- ❖ Joint shaft
- ❖ Cutting head suspension
- ❖ Rear guard
- ❖ Cutting head
- ❖ Control box

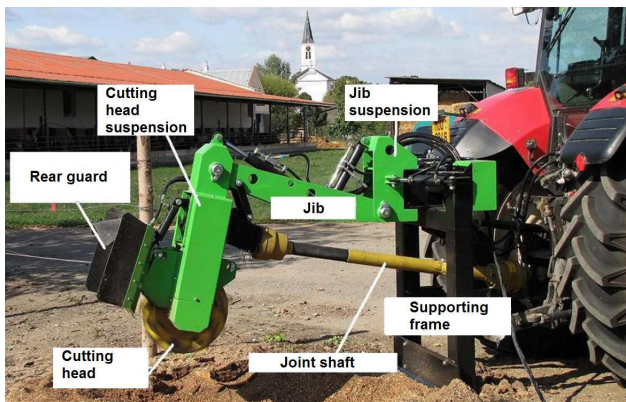

❖ **Supporting frame**

It is welded from hollow-space profiles. In the front part there is a three-point hitch welded and intended for coupling to a tractor. In the bottom profiles there are retractable supporting feet for compensation of surface irregularities. In the top part there is a jib suspension hinged and also holders for hydraulic cylinders.

❖ **Jib suspension**

It is intended for swinging of the cutter jib. The suspension itself provides swinging motion against the supporting frame. The jib, hinged in the suspension, can move up and down. The jib suspension is controlled by hydraulic cylinders.

❖ **Jib**

It is a hinged bearer, made of welded steel profiles, completed with the cutting head suspension attached.

❖ **Joint shaft**

It is designed for transmission of the torque from the PTO shaft to the input shaft of the V-belt gearing.

❖ **Cutting head suspension**

With its closed design it is hinged on the jib and linked to a hydraulic cylinder. The angle gearbox attached to the suspension is intended for transmission of the torque to the drive pulley and through V-belts to the cutting head with blades.

❖ **Rear guard**

This height-adjustable guard protects the cutting head preventing unwished ejection of wooden chips. It is equipped with a chain and a rubber shield. Both safety elements protect the ambient space against ejected particles.

❖ **Cutting head**

The cutting head is designed for the own cutting action. Its cutting blades are bolted to the head in pairs as the RH and LH blade. The cutting head is powered by V-belts that can absorb eventual hits of the blades on the stump being cut. The inactive parts (being disengaged) are covered by the guard.

❖ **Control box**

This controller can move the respective machine parts forward/backward and to the right/left by means of keys.

Actual control depends on the cutter model:

FZ 560 T-M:

Mechanically: by means of control levers under a hinged cover.

FZ 560 T-RC:

Remote control: it is in fact a multifunctional controller fed by 12 V from the tractor – its connector is to be plugged in a socket intended for a portable lamp.

## Technical Parameters

Parameter	Unit	Value
Overall length	mm	2180
Overall width	mm	1040
Overall height	mm	1735
Gross weight	kg	526
<b>Cutting head</b>		
Diameter	mm	560 w/ blades; 496 w/o blades
Operating width	mm	73
Number of blades	-	18
Drive	-	joint shaft, 4x V-belts XPB 17x1500 Lw
Input power	HP	30 – 50
<b>Cutting range</b>		
Above-ground	mm	700
Under-ground	mm	600
Stump diameter	mm	1500

<b>Coupling</b>		
Three-point linkage	-	category 1, 2
PTO shaft speed	rpm	540
<b>Remote control</b>		
Type		SCANRECO RC 400 (Sweden)
Transmitter frequency	MHz	433,05 – 434,79
Transmitter output	mW	max. 10

## Maintenance

- Any servicing of the cutter should be carried out by authorised persons only.
- Any servicing or repair is allowed to be done only if the machine was put out of operation.
- Check up the machine for completeness and its general condition.
- After every working shift check up tightening of bolted joints, especially rotating parts and completeness of other parts, such as fixation of blades.
- Check up the V-belts for tightness and wear.
- Keep regular intervals for lubrication of cutting head bearings.
- Check up condition of blades regularly.
- Check up hydraulic hoses for wear. Replace them if necessary or every five years at least.

## Lubrication

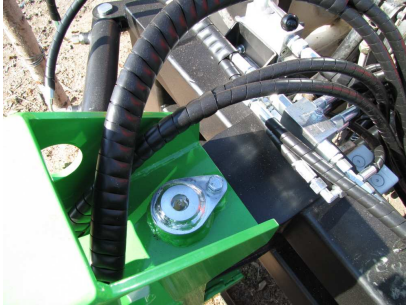

Grease cup of jib suspension  
Lubrication every 50 running hrs



Grease cups of cutting head suspension  
Lubrication every 50 running hrs



Grease cups of V-belt gearing in suspension box wall  
 Lubrication every 50 running hrs

## Replacment of Blades and Regrinding



Blades edge regrinding requires high demands for keeping optimal cutting edge shape. While grinding it is necessary to keep its optimal geometry. The right shape prolongs blade service life.

While regrinding it is necessary to keep the same weight of particular blades because of balance of their rotating mass. For grinding use always a grinder with a magnetic table and a special fixture. We recommend calling the manufacturer Laski s.r.o. for assistance.

When reassembling, be aware that the blades are in pairs as the RH and LH ones. In addition to that they can be straight or bent.

Replacement of the LASKI blades:

- Loosen the bolts (10).
- Replace the blades by new ones.
- Tighten the new blades slightly.
- Use the torque wrench and tighten the bolts with a **torque of 110 Nm**.
- For replacement of worn or damaged blades use always original Laski blades and bolts only (10).
- While replacing, proceed very carefully.
- Before replacement the machine must be secured against overturning.
- **Be aware that the Laski blades are not fully interchangeable with each other. Do not confuse the right with left ones and the straight with bent ones.**

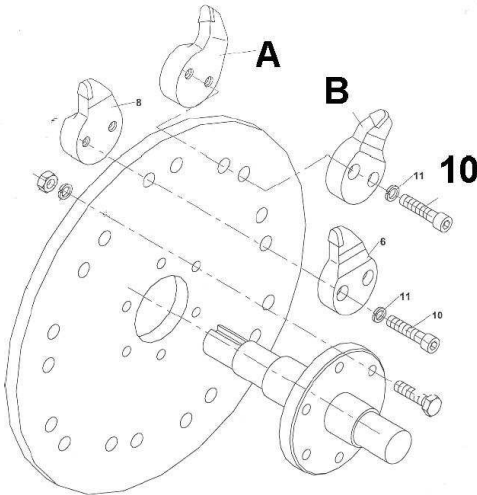

### Remote Control and Battery Charger

There is one charger available with this machine for voltages 12 to 30 V DC. The other option is 240 V with an adapter. The battery pack is rechargeable and of Nickel Cadmium (NiCd) type. The normal charging time for an empty uncharged battery, is approximately 12-14 hours. The battery charger is constructed so that no damage will occur from long continuous charging. The batteries effective operation time is about 8 hours on one charge. When the battery is approaching the time for charging, the control unit beeps three times as a warning and at the same time the LED starts to blink on the control unit. The battery must be used until the LED goes out, after which it can be changed. If the battery capacity is too low, the control unit cannot be activated.

In order to reduce battery loading and for safety reasons, the control unit is turned off automatically, after the unit has been idle for more than approximately five minutes.

Should the battery be fully discharged, it can be replaced by a new one. The battery is accessible under the cover in the bottom of the remote control unit.

The LED on the remote control box indicates actual condition of the battery





## Maintenance Intervals

<b>Oil change in angle gearbox</b> SAE90 or SAE90EP	The first oil change after first 100 working hours and next changes every 1000 hrs. Change the oil always when the machine is turned off and still warm. Discharge the used oil into a bin. An oil charge is about 1,5 l.
<b>Pinned joints</b>	Lubrication every 50 running hrs with grease.
<b>Cutting head</b>	Checks always after hitting hard obstacles or foreign materials in the stump to be cut.
<b>Cleaning of product</b>	Always after cutting, respectively according to actual fouling. Keep gearbox and V-belt gearing always clean.
<b>Electric installation</b>	Protect all wires against contact with oil products and contingent damage. Avoid any risk of supply cable squeezing.
<b>Hydraulic hoses</b>	Check up hydraulic hoses for wear. Replace them if necessary or every five years at least.

## Failures and Troubleshooting

Failure	Cause	Remedy
Insufficient cutting quality	Blunt blades	Remove and regrind blades. If worn, replace them for new ones.
	Low speed	Speed up tractor engine
	Blades wrongly fixed	Check out and reassemble if necessary

	Flow limiters wrongly set up	Check out and reset	
	Low oil flow from tractor	Replace (repair) tractor	
	V-belts slack	Tighten/replace V-belts	
Bearings overheated	Insufficient lubrication or wrong lubricant used	Lubrication and lubricants should be in accordance with recommended intervals and sorts	
	Too high speed of input shaft speed	Optimal PTO shaft speed should not exceed 540 rpm	
	Bearing loosened	Tighten up bearing housing bolts with required torque	
	Bearing noise increased	Replacement	
<u>FZ 560 T-RC:</u> No signal	No connection to tractor	Plug the supply cable in the portable lamp socket	
	Discharged battery Faulty charger Faulty remote control box	Recharge the battery	SERVICE SERVICE

**Note:** The note "SERVICE" in the "Remedy" column means that this operation should be done by an authorised service only.

## Waste Disposal

Any waste materials resulting from the machine operation should be disposed in accordance with laws and regulations valid in the given country.

Protect nature and water resources against used oil, lubricants and filter elements.

Any parts of the machine should be disposed in accordance with laws and regulations valid in the given country.

## Warranty

The manufacturer provides warranty on this product for a period as stated in the enclosed Letter of Indemnity. This warranty period begins upon delivery to the customer.

This warranty covers all failures resulted from faulty assembly, manufacture and materials.

The manufacturer bears no responsibility for damages resulted from user's wrong usage, such as:

- Usage by an unauthorised person.

- Unauthorised changes, repairs and actions on the machine.
- Usage of unoriginal spare parts or parts intended for other models.
- Disobedience to instructions for use.
- Damage of the machine caused by faulty handling, maintenance or overloading.
- This warranty does not cover faults resulted from damages caused by the user.
- This warranty does not cover parts being subject to ordinary wear and tear.
- This warranty does not cover any damage of machine caused by usage of unoriginal spare parts.
- This warranty does not cover consequences resulted from weather effects.

Any warranty claims must be submitted in writing with papers concerning acceptance for warranty or post-warranty repair.

## Maintenance and Servicing

The following table form serves for notes of all actions within service life of the machine. Complete the form with description of the given action, changed parts and signature of a competent technician.

Description of work and changed parts	Technician's signature